

BEA-635

350 Watt

- Noise immunity for industrial sectors
- High-quality electrolytic capacitors (+105 °C)
- Operating temperature -10...+70 °C

The 350 W PC power supply BEA-635 is distinguished by very high reliability and long service life. By its integrated 4 kV surge input filter the BEA-635 is also suitable for highly demanding industrial applications. Within an ambient temperature range of -10 up to +50 °C full power can be supplied continuously without restrictions. The temperature regulated ball-bearing fan provides a tachometer signal and can continuously be monitored by the board, which is very important with regard to system reliability.



Technical data

Input voltage	90...264 V AC, active PFC
Input frequency	47...63 Hz
Input current	7 A (115 V AC) / 3.5 A (230 V AC)
Inrush current	48 A (115 V AC) / 88 A (264 V AC)
Efficiency	≥75 %, 230 V AC / ≥70 %, 115 V AC (full load)
Hold up time	>16 ms
Power-Good-Signal	Switch on delay 100...500 ms Switch off delay 1 ms
Protection	Short circuit protection: At each output, switch off / +5 V _{sb} , auto-recovery Overload protection: 110...150 %, switch off Overvoltage protection: +3.3 V (+3.9...+4.3 V), +5 V (+5.7...+6.5 V), +12 V (+13.6...+15 V)
Insulation voltage	Input / Chassis 3100 VDC Input / Output 4242 VDC
Earth leakage current	<3.5 mA, 115 V AC / 230 V AC
Safety / EMC	TÜV, UL, CE, CCC, EN 61000-6-2, EN 61000-6-4, EN 62368-1
Temperature	Operating: -10...+70 °C / Storage: -20...+80 °C
Derating	Between +50...+70 °C, 1 % / °C
MTBF	180 000 h according to MIL-HDBK-217F at +50 °C without fan
Max. operation altitude	2000 m
Humidity	Operating: 10...85 % RH, non-condensing / Storage: 10...90 % RH, non-condensing
Dimensions (WxDxH)	150 x 140 x 86 mm ±0.5 mm
Weight (net)	1.95 kg

Article No.	Output voltage	Output current		Load regulation	Ripple & Noise
		min	max		
BEA-635	+3.3 V	0 A	28 A	±5 %	50 mV
	+5 V	0.5 A	35 A	±5 %	50 mV
	+12 V	0.5 A	26 A	+7/-5 %	120 mV
	-12 V	0 A	0.8 A	±5 %	150 mV
	-5 V	0 A	0.5 A	±5 %	150 mV
	+5 V _{sb}	0 A	2 A	±5 %	50 mV

Max. output is 350 W, combined max. output current at +3.3 V and +5 V must not exceed 45 A. For temperatures <20 °C a higher minimal output current is required. Ripple and Noise was measured by a 20 MHz bandwidth limited oscilloscope with connected 220 µF electrolytic capacitor and 0.1 µF ceramic capacitor at each output. During a cross regulation test we recommend to keep the channel with higher output load at 80 % of its max. power and the channel with lower output load at 20 % of its max. power.

As a power component this PSU is for assembly purposes only and must not be operated in unassembled condition. The final assembly has to comply with the valid EMC and safety standards.

Drawing BEA-635

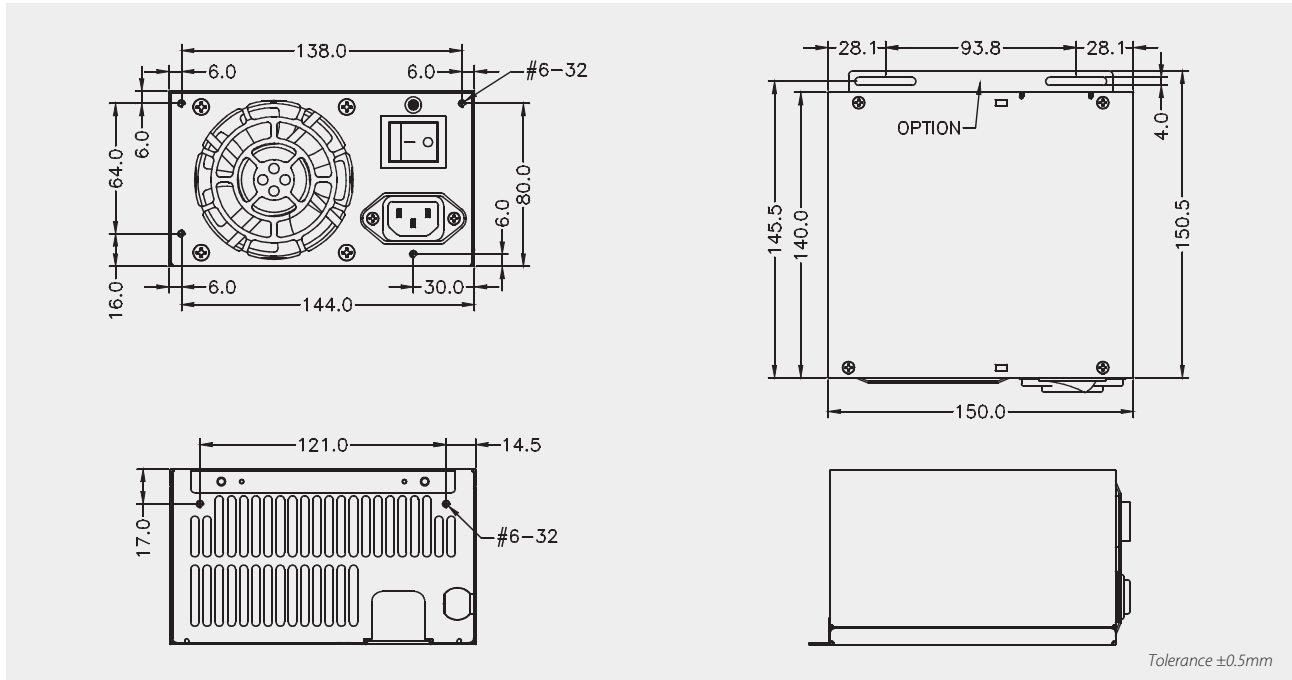

Cable harness BEA-635

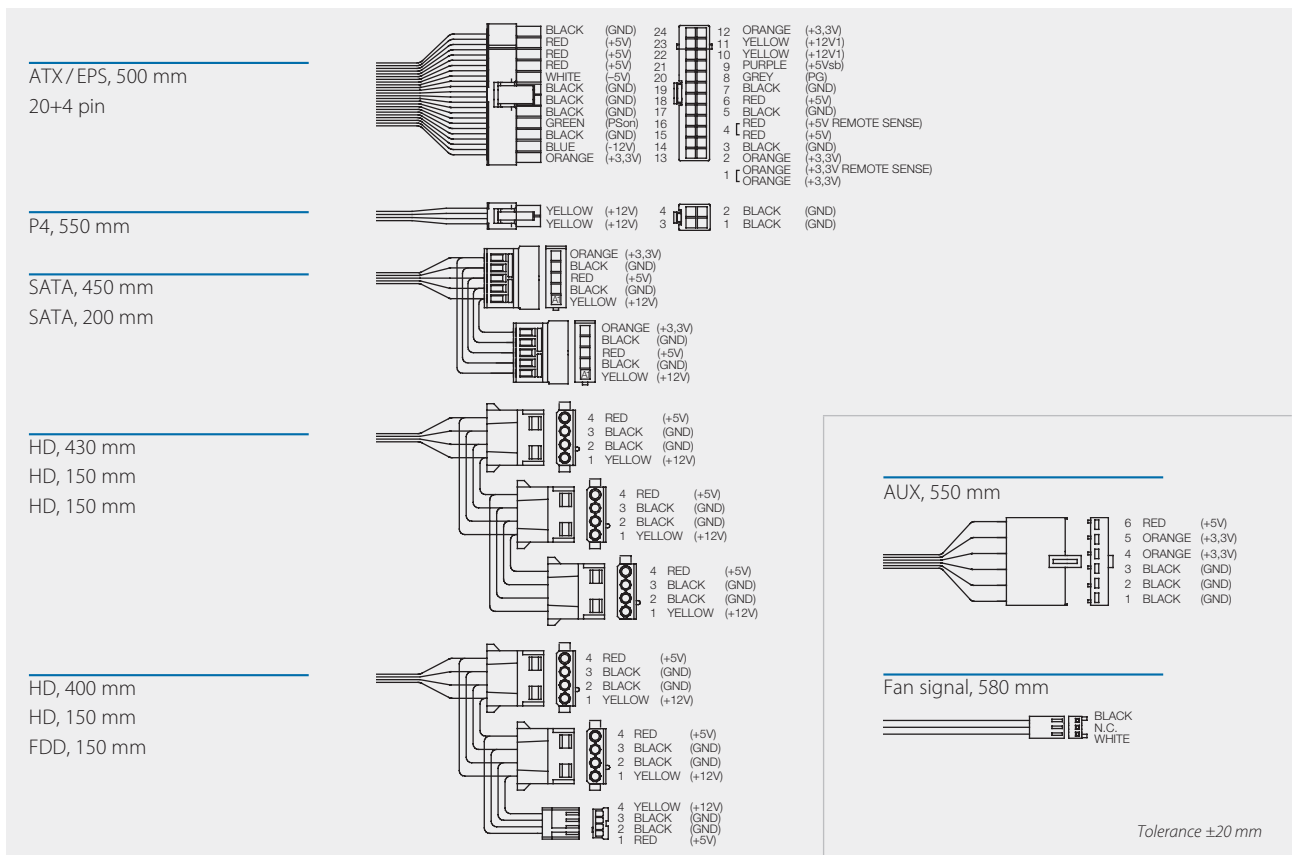

Specification is subject to change without notice. Errors excepted. Status as at: 09.07.2020

Optional accessory >>> For detailed information please visit our website www.bicker.de and refer to the article number.

Article No.	Description
X1-132	Power cord with European IEC-60320-C13 connector