

eNSP-300P-USB

200 Watt

- Industrial PC power supply with UPS function
- USB interface
- Temperature range 0...+50 °C

The UPS PC power supply eNSP-300P-USB uniquely combines the function of a PC power supply with that of a UPS. The power supply safely bridges sudden mains voltage drops as well as total power failure. The installation of the eNSP-300P-USB is compatible with conventional PC power supplies. Energy is provided by an external battery pack in the practical 5.25" format. Via an interface cable, which is part of the delivery, the power supply can communicate with an optional UPS management software.



UPS function

Technical data	
Input voltage	85...264 VAC / active PFC
Input frequency	47...63 Hz
Input current	2.6 A max. (115 VAC) / 1.3 A max. (230 VAC)
Inrush current	<50 A (100 VAC) / <100 A (240 VAC)
Efficiency	71 % typ. (240 VAC)
Power-Good-Signal	Switch on delay 100...500 ms Switch off delay 1 ms
Protection	Short circuit protection: at each output Overvoltage protection: +5 V (5.74...7.0 V) / +3.3 V (3.76...4.3 V) / +12 V (13.4...15.6 V) Switch off
Earth leakage current	<1 mA / 240 VAC
Safety / EMC	EN 60950-1, IEC 60950-1, UL 60950-1, CE
Operating temperature	0...+50 °C
Derating	+45...+50 °C, 4 % / °C
MTBF	105 000 h
Storage temperature	-25...+70 °C
Operating humidity	10 % bis 90 % RH, non-condensing
Dimensions (WxDxH)	150 x 155 x 86 mm ±0.5 mm
Weight (net)	2 kg

Product specific data	
Battery types	BP-2423N-B1: (2 x 12 V / 2.3 Ah), maintenance-free lead batteries RBS01A-P24/2.2L: (2 x 12 V / 2.3 Ah), maintenance-free lead batteries in clip-on frame
Backup time	BP-2423N-B1: app. 3 min. at 100 % load, app. 9 min. at 50 % load RBS01A-P24/2.2L: app. 3 min. at 100 % load, app. 9 min. at 50 % load
Battery charge current	0.5 A max. ±0.2 A, battery is also charged when PC is switched off
Battery charger	27.3 V, with temperature compensation
Battery monitoring	20 V ±0.5 V „Battery low“ switching point 19 V ±0.5 V „Shut down“ switching point

Article No.	Output voltage	Output current			Load regulation	Ripple & Noise
		min	max	peak		
eNSP-300P-USB	+3.3 V	0 A	14 A	28 A	±4 %	50 mV
	+5 V	1 A	21 A	30 A	±4 %	50 mV
	+12 V	0 A	10 A	15 A	±10 %	150 mV
	-5 V	0 A	0.3 A	0.3 A	±5 %	50 mV
	-12 V	0 A	0.8 A	0.8 A	±5 %	100 mV
	+5 V _{sb}	0 A	1.5 A	2.5 A	±5 %	50 mV

Combined max. output at +3.3 V and +5 V must not exceed 125 W (180 W peak). Combined max. output at +3.3 V, +5 V, and 12 V must not exceed 185 W (280 W peak). From a load of 12 V / >7 A onwards a minimum load of >1.5 A is required at +5 V. From a load of +5 V / 21 A onwards a minimum load of app. 0.3 A is required at +12 V. Peak output can be 303 W for up to 3 seconds. Ripple and noise was measured by a 20 MHz oscilloscope with connected 10 µF electrolytic capacitor and 0.1 µF ceramic capacitor at each output. This power supply is for assembly purposes only and it must not be operated in unassembled condition. The final assembly has to comply with the valid EMC standards.

Drawing eNSP-300P-USB

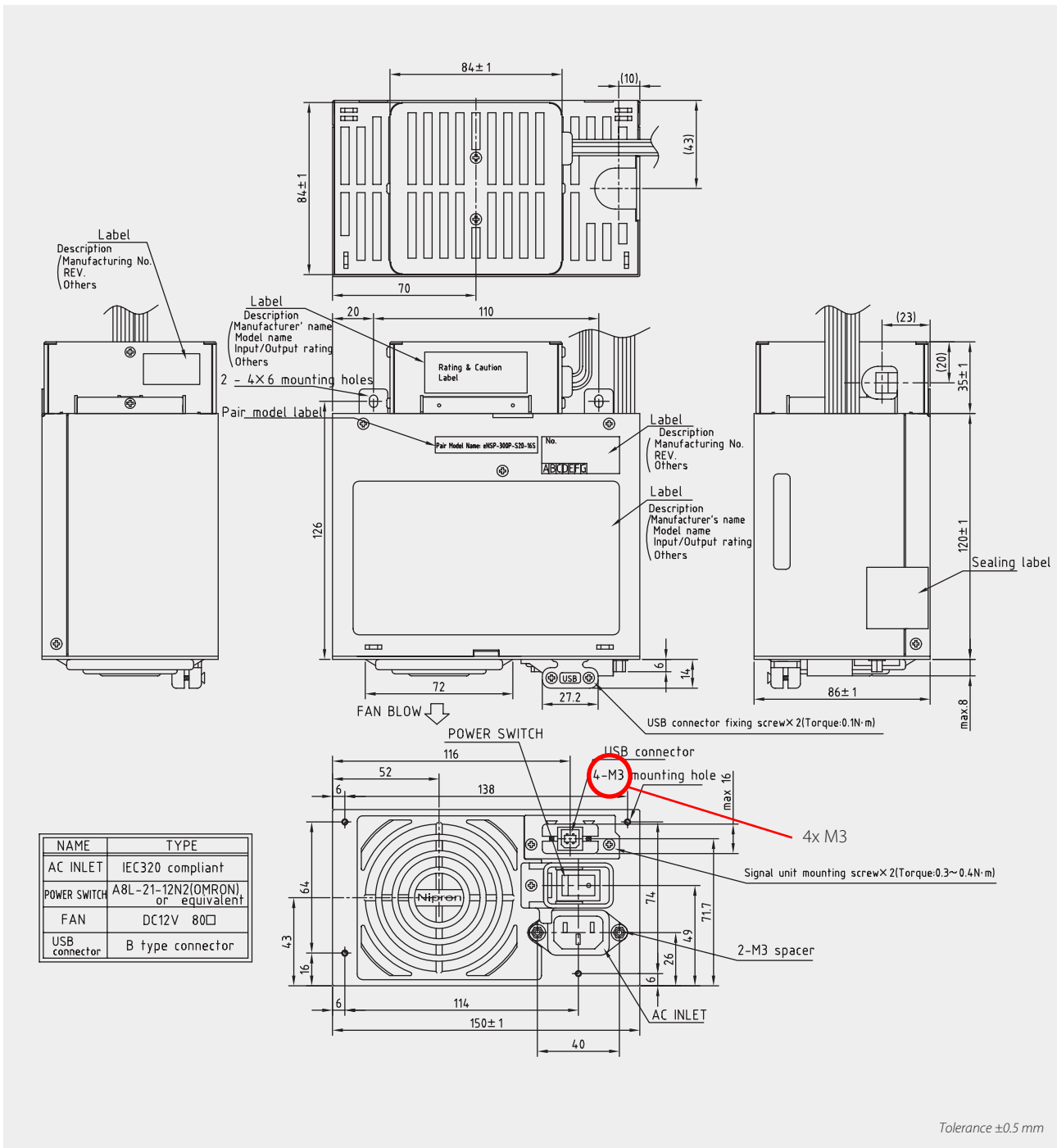

Cable harness eNSP-300P-USB (Included in delivery)

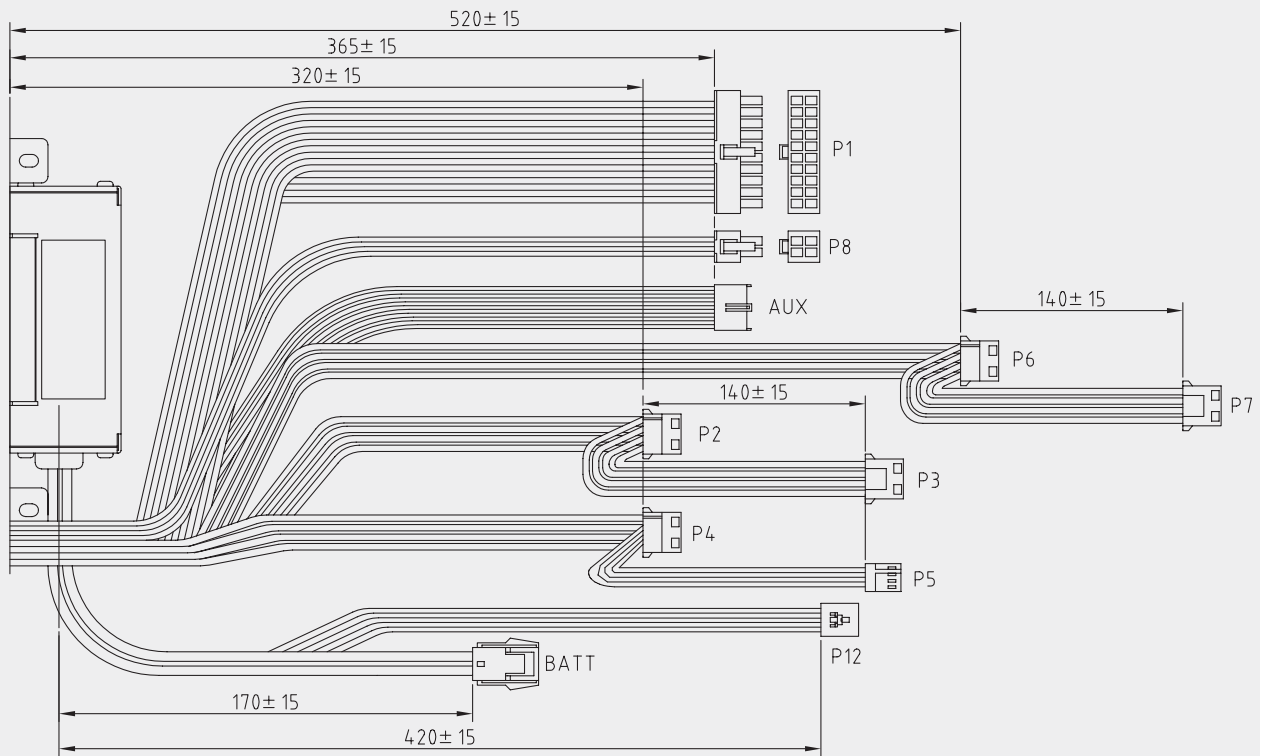

Pin assignment of backside connector

P2, P3, P4, P6, P7 (HD)		P8 (P4)		P1(ATX)		P1 (ATX)	
PIN No.	Function	PIN No.	Function	PIN No.	Function	PIN No.	Function
1	+12 VDC	1	COM	1	+3.3 VDC	11	+3.3 VDC default sense
2	COM	2	COM	2	+3.3 VDC	12	+3.3 VDC
3	COM	3	+12 VDC	3	COM	13	-12 VDC
4	+5 VDC	4	+12 VDC	4	+5 VDC	14	COM
				5	COM	15	PS-ON#
				6	+5 VDC	16	COM
				7	COM	17	COM
				8	PWR-OK	18	-5 VDC
				9	+5 V _{SB}	19	+5 VDC
				10	+12 VDC	20	+5 VDC
P5 (FDD)		AUX					
PIN No.	Function	PIN No.	Function				
1	+5 VDC	1	COM				
2	COM	2	COM				
3	COM	3	COM				
4	+12 VDC	4	+3.3 VDC				
		5	+3.3 VDC				
		6	+5 VDC				

CB-USB01, 500 mm

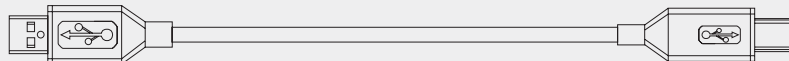

Tolerance: ±15 mm

Pin assignment of front connector

Internal interface P12 open collector

AC Fail	Output In case of mains voltage failure, level is high. In case of mains voltage failure, level is low.
Battery LOW	Output If battery is low, level is high. If battery is ok, level is low.
Shutdown	Input Signal to switch off the PC power supply in UPS mode. Level must be ≤ 0.4 VDC for >15 ms.

Internal Interface

P12 Open Collector	
PIN No.	Function
1	COM
2	Shut down
3	AC fail
4	Batt. low
5	N.C.
6	Fan alarm

USB Interface

USB	
PIN No.	Function
1	V BUS
2	D-
3	D+
4	COM

Battery connector

BATT	
PIN No.	Function
1	Batt +VE
2	Batt -VE

Specification is subject to change without notice. Errors excepted. Status as at: 09.12.2011

ENSP3-REBOOT

Automatic start and reboot board

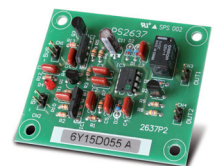

Optional accessory ▷▷▷ For detailed information please visit our website www.bicker.de and refer to the article number.

Article No.	Description
BP-2423N-B1	Battery pack with maintenance-free lead batteries
RBS01A-P24/2.2L	Battery pack with maintenance-free removable lead batteries in clip-on frame
RUPS 2000-B1	UPS Management Software (CD-ROM)
ENSP3-REBOOT	Automatic start and reboot board

Windows® is a trademark of the Microsoft Corp.